

NO DIG *Equipment*

The Trenchless Technology Specialists



Vacuum Excavator VM400 D



Three Stage filtration system

Our VM range of Vacuum Excavators are incorporated with a three stage filtration system, including a cyclonic dust separation unit, with a 5 micron washable poly filter element. This three stage filtration system is a very efficient dust separation process, which minimises the frequency of filter cleaning.

Powerful positive displacement blower

High level continuous flow tri-lobe vacuum pump, without the need to prime or need for the inlet hose to be submerged. Ideal for potholing, service locating, mud removal or general cleanup.

Superior Corrosion Protection

Our VM400 has a fully hot dip galvanised spoil tank, improving durability and minimising rust, adding extra years to the life of our Vacuum Excavators and offers the best protection against our harsh Australian climate.

Hydraulic operated dumping

Remote control operated hydraulic tilt, for quick and easy emptying of the spoil tank.

High pressure water system

A 200 L built in water tank coupled to a powerful 3500 Psi triplex piston pumps enable you to quickly and safely pothole to determine the exact location of underground utilities and drilling equipment.

What type of work can you do with a Vacuum Excavator VM400?

- Cleaning Telecom pits & lines
- Underground service locating
- Clean up construction sites
- Install fence posts
- Gas pipe maintenance
- Sewer pipe maintenance
- Installing NBN optical fibre through pipe
- and much more

VM400 Vacuum Excavation Machines includes:

- Self contained skid, trailer or truck mounting
- 34.9 Hp Kohler Diesel
- 3" dia Vacuum Suction Hose x 5m long
- 400 Litre Spoil Tank
- 550cfm Blower, producing ultra efficient vacuum
- 3500psi High Pressure Triplex Water Pump



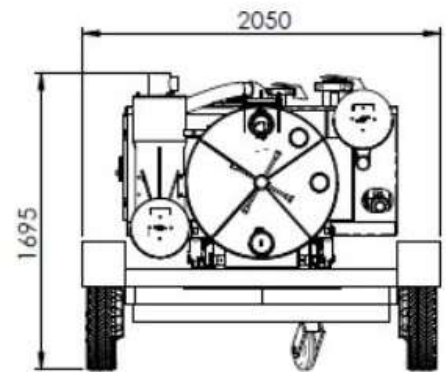
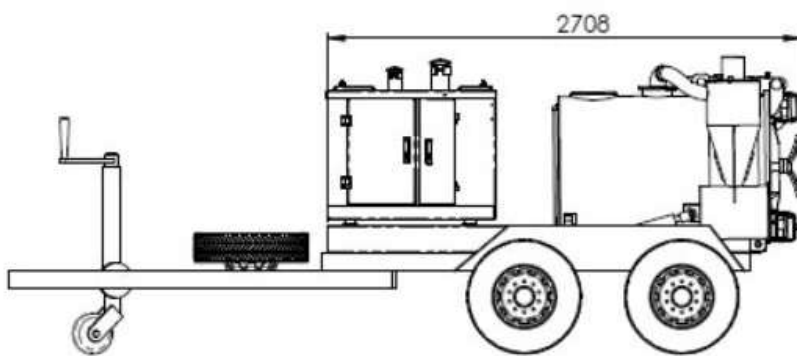
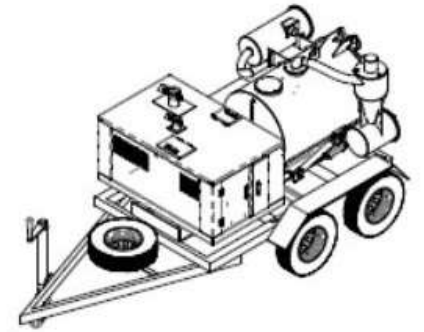
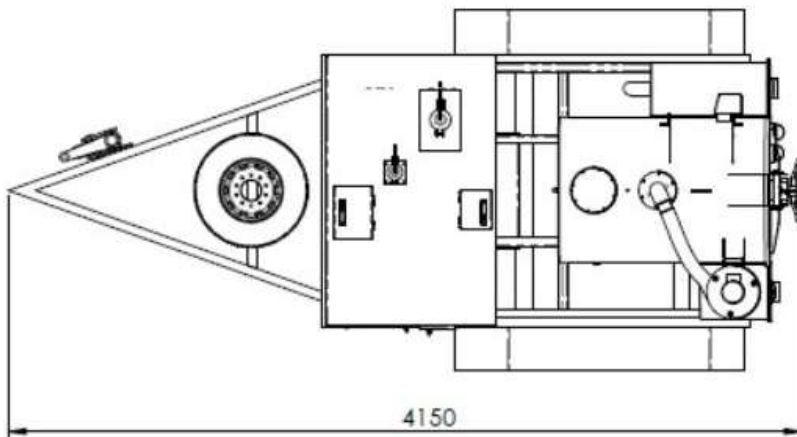

VM400 Vacuum Excavator

Vacuum System	550 CFM blower, c/w- 3" dia hose (318mm Hg, 15"Hg)
Diesel Engine	34.9 Hp Kohler KDW1404 Diesel Engine
Spoil Storage Tank	400 Litre with Hydraulic Tilting
High Pressure Water System	3500psi @ 15 Lpm
Water Tank	200 Litres
Dry Weight (excluding trailer)	920 Kg

Optional Extras

Heavy Duty Trailer	2.2T, (350 Kg)
Skid Frame	c/w- forklift points
Double Jet Digging Wand	6.5" dia (165 mm) head
Suction Hose Extension	10 meters in 3" or 4"

NO DIG *Equipment*

The Trenchless Technology Specialists

Address: 15 Wildfire Rd, Maddington WA 6109

Ph : 08 9493 0642

sales@NoDigEquipment.com

www.NoDigEquipment.com.au