

NO DIG *Equipment*

The Trenchless Technology Specialists



McCloskey D15

HDD Drill

NODIG Equipment have teamed up with McCloskey International (Canada) to bring to you the most powerful Horizontal Directional Drilling Machine in its class.

With an advanced electric/hydraulic system the D15 HDD Machine delivers more horsepower to the ground, better fuel efficiency, and a guaranteed 15,000 lbs of thrust/pullback, whilst simultaneously delivering 1600 lbft of rotation respectively.

SMOOTH OPERATION

The D15 utilises a single 'Hydraulic Compound Cylinder' which delivers high performance with less maintenance.



MUD MIXING SYSTEM

The Performix SL300 is a complete, self-contained 300-gallon mixing solution ready to work. Its compact footprint makes it an ideal solution for compact drilling machines.



HARD ROCK READY

The McCloskey D15 Machine is the only machine in its class, designed to run with a down the hole hammer, allowing you to drill in the toughest of ground conditions.



HIGH VISIBILITY

With the option of manual or automatic breakout, the 'Open Top Vice' provides excellent visibility allowing the operator to monitor rod connections and breakouts.



SELF-DIAGNOSTICS

Optional interactive diagnostics automatically alert operators to service and supply needs and can order parts and regularly schedule maintenance.



SPECIFICATIONS

GENERAL DIMENSIONS

Length	14.4'	4.37 m
Height	5.51'	1.68 m
Width	4.2'	1.28 m
Weight	4.4 tonne	

DRILL RODS

Type	Firestick 1	
Length	6'	1.83m
Pipe Diameter	1.9"	48.3mm
Rods (33)	60 meters	198ft

DRILLING FLUID SYSTEM

Maximum Fluid Pressure	1000 PSI	69 Bar
Maximum Fluid Flow	25 GPM	94.6 LPM
Mud Mixing System	300 Gallon	1100 L

OPERATIONAL

Thrust	15,000 lbs	6804 kg
Pullback	15,000 lbs	6804 kg
Rotary Torque	1600 lbft	2170 Nm
Rotary Speed (Maximum)	130 RPM	
Minimum Bore Diameter	2.5"	63.5 mm
Ground Travel Speed	3.3 MPH	5.3 KM/H
Joystick	Multifunctional	
Thrust Cylinder	Compound Type	

FLUID CAPACITIES

Diesel Fuel Tank	25 gal	94.6 L
Hydraulic Tank	27.4 gal	103.7 L

HYDRAULIC SYSTEM

Auxiliary Pump Flow at Max RPM	17 gpm	64.4 L/min
Auxiliary Pump Relief Pressure	2800 PSI	193 Bar
Thrust/Pullback Pump Flow at Max RPM	30 gpm	113.5 L/min
Thrust/Pullback Pump Relief Pressure	3750 PSI	259 Bar
Rotation Pump Flow at Max RPM	30 gpm	113.7 L/min
Rotation Pump Relief Pressure	3000 PSI	207 Bar

ENGINE

Make and Model	Kubota V2403MT Tier 4i
Fuel Type	Diesel
Maximum Engine RPM	2700 RPM
Gross Horsepower	59 HP (44 KW)
Max Torque	122 lbft(165.4 Nm)
Displacement	148.53 cu. in.
Number of Cylinders	4
Cooling Method	Liquid
Aspiration	Turbo Charged
Air Cleaner	Donaldson
EPA Certification Family	Tier 4i FLEX

MUD MIXING SYSTEM

Make and Model	Performix® SL300	
Tank Capacity	300 gallons (1100 L)	
Engine	Kohler® Command CS Pro 6 Hp (4.5 Kw) engine	
Pump	170-gpm (11 lps)	
Fuel Tank	6-gallon (23 L)	
Tank Guns	3	
Connections	2" (5.1 cm) suction and discharge ports	
Length: 2500 mm	Width: 1000 mm	Height: 1400 mm

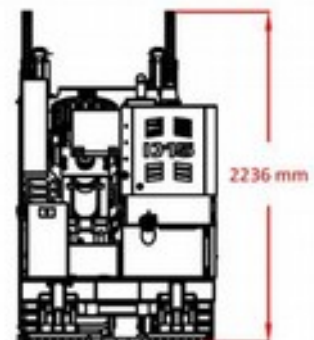
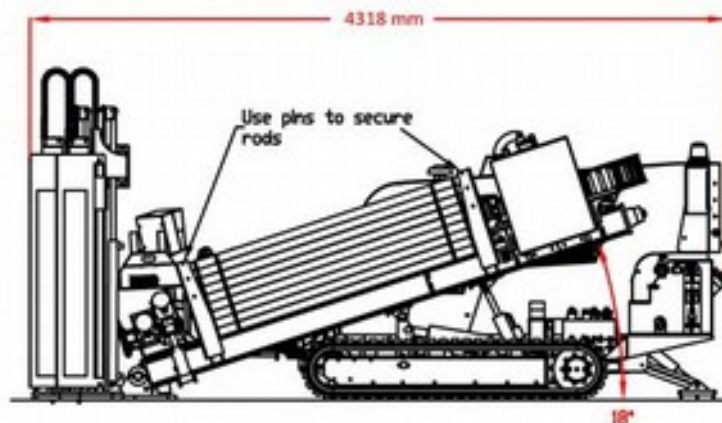



NO DIG *Equipment*

The Trenchless Technology Specialists



NO DIG *Equipment*

The Trenchless Technology Specialists

Address: 15 Wildfire Rd, Maddington WA 6109
Postal: PO Box 2, Maddington WA 6989

Ph : 08 9493 0642
Fax : 08 9493 0672

www.NoDigEquipment.com.au
sales@NoDigEquipment.com.au

